

# Hazardous Location GRP Strobe Light



Model WV450XD and WV450XE

## GLASS REINFORCED POLYESTER DESIGN FOR LOW MAINTENANCE AND CORROSION RESISTANCE

- Available in 24-48VDC, 110VAC, 220-248VAC
- Available in 5, 10 and 15 Joule Units
- Seven available lens colors: red, amber, yellow, blue, green, clear and magenta
- 316 Stainless steel mounting bracket included
- Toughened, impact resistant dome
- IP66
- Corrosion free GRP (glass reinforced polyester)
- Included dome guard
- Two M20 entries standard
- Zone rated, IECEx

ATEX EExd IIB + H2 T4 + T3

The Federal Signal Model WV450X Hazardous Location GRP Strobe Light is designed to serve the needs of rugged land-based and offshore industrial applications that demand reliable, long life operation while complying with stringent International approval requirements.

The Federal Signal Model WV450X Hazardous Location GRP Strobe Light utilizes the latest technology in non-metallic housing construction. The housing of the WV450X is comprised entirely of Glass Reinforced Polyester (GRP) which makes the product corrosion free and lighter than a comparable metallic fixture. The fact that the WV450X is corrosion free also makes the product safer, and “maintenance-free” by eliminating the need to regularly inspect the flame path. An electro-polished stainless steel dome guard is also provided for protection of the glass lens in the event of accidental impact.

Two versions of the WV450X are available. The “D” version of the product (WV450XD) comes standard with a stainless steel mounting bracket for wall mounting or fastening to a vertical surface. Two holes are tapped for M20 thread in the bottom of the product allowing for field gland connection. The “E” version of the product (WV450XE) includes the same features as the WV450XD, but incorporates a terminal chamber with three M20 tapped holes on the very bottom of the fixture. This terminal chamber is designed to house field terminations and through going power supplies.

The WV450X is available in seven standard colors and three voltage ranges to satisfy most applications. There are also three different Joule output ratings available for each model and each voltage range, providing the ability to tailor the light output and current draw for a given area. The WV450X is ATEX, IECEx approved, making it ideal for applications that require International third party safety standards.

Model	Operating Voltage	Max Operating Current	Temperature Code	Flash Rate	Lamp Life*
WV450	24-48VDC	0.94/0.48 A @ 24-48VDC	T4	60	10,000 hrs
	110VAC	0.57 A @ 110VAC 50/60Hz	T3	60	10,000 hrs
	220-248VAC	0.30 A @ 220-248VAC 50/60Hz	T3	60	10,000 hrs

\* Optimal Hours under ideal conditions



# HAZARDOUS GRP STROBE (WV450XD/WV450XE)

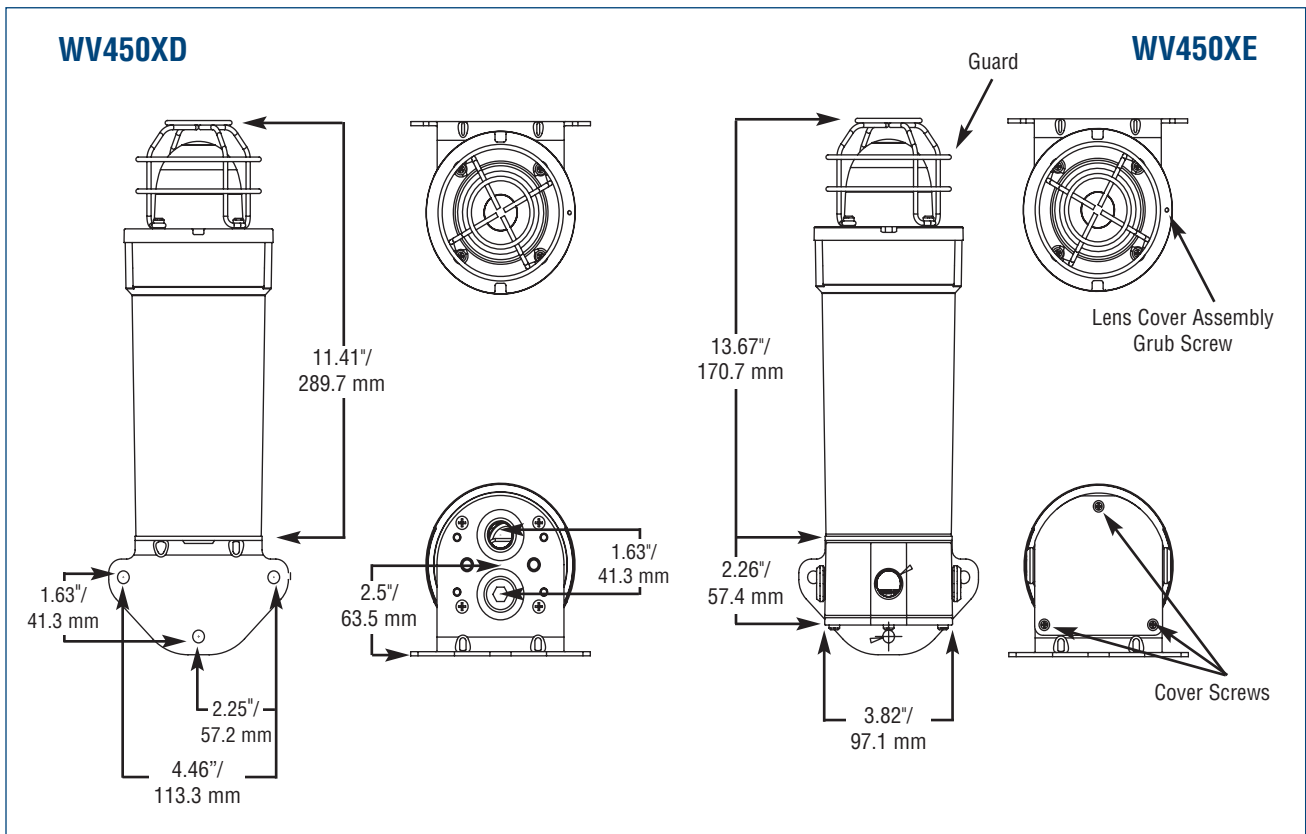

## SPECIFICATIONS

### Operating Temperatures:

“d” version without terminal chamber

ATEX -55°C to 55°C (-67°F to 131°F)

IECEX -20°C to 55°C (-4°F to 131°F)

“e” version with terminal chamber

ATEX -20°C to 55°C (-22°F to 131°F)

IECEX -20°C to 55°C (-4°F to 131°F)

### WV450XD

NET Weight: 7.1 lbs. 3.23 kg

Shipping Weight: 8.6 lbs. 3.88 kg

Height: 11.41” 289.7 mm

Diameter: 4.46” 113.3 mm

### WV450XE

NET Weight: 8.6 lbs. 3.9 kg

Shipping Weight: 10.0 lbs. 4.54 kg

Height: 13.67” 170.7 mm

Diameter: 3.82” 97.1 mm

Certificate Number: IECEx UL 06.0010X

06 UL DEMKO ATEX 0425693X

## HOW TO ORDER

- Specify Model Number
- Specify Construction Series, “D” or “E”
- Specify Joule Output
- Specify Voltage Range
- Specify Lens Color
- Please contact factory for model selection